

**United States Court of Appeals  
for the Federal Circuit**

---

**DONNER TECHNOLOGY, LLC,**  
*Appellant*

v.

**PRO STAGE GEAR, LLC,**  
*Appellee*

---

2020-1104

---

Appeal from the United States Patent and Trademark Office, Patent Trial and Appeal Board in No. IPR2018-00708.

---

Decided: November 9, 2020

---

SCOTT AMY, Thomas Horstemeyer LLP, Atlanta, GA, for appellant. Also represented by ROBERT GRAVOIS, WESLEY AUSTIN ROBERTS.

DOUGLAS JOHNSON, Miller & Martin PLLC, Chattanooga, TN, for appellee. Also represented by M. ELLIS LORD, ROBERT F. PARSLEY; PHARAN A. EVANS, Atlanta, GA.

---

Before PROST, *Chief Judge*, DYK and HUGHES, *Circuit Judges*.

PROST, *Chief Judge*.

Donner Technology, LLC (“Donner”) petitioned for inter partes review (“IPR”) of U.S. Patent No. 6,459,023 (“the ’023 patent”), challenging various claims as obvious under 35 U.S.C. § 103. Donner’s petition set forth three grounds of unpatentability, all relying at least in part on the teachings of U.S. Patent No. 3,504,311 (“Mullen”). The Patent Trial and Appeal Board (“Board”) rejected these challenges on the ground that Donner did not prove that Mullen is analogous art. *Donner Tech., LLC v. Pro Stage Gear, LLC*, No. IPR2018-00708, 2019 WL 4020204, at \*10–11 (P.T.A.B. Aug. 26, 2019) (“*Decision*”). Donner appealed. We vacate and remand.

## BACKGROUND

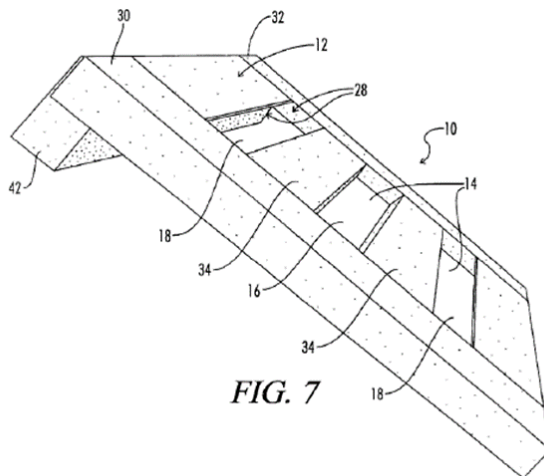
### I

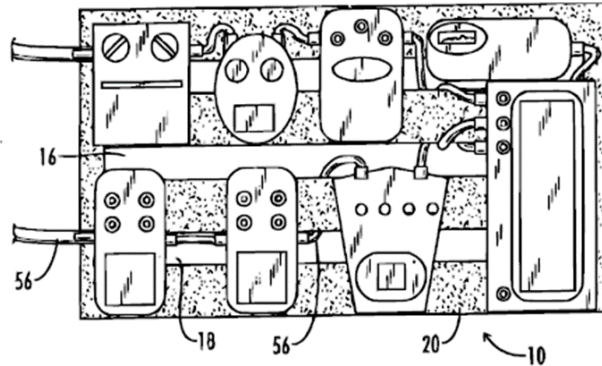
Guitar effects pedals are electronic devices that affect the amplified sound of a guitar. These pedals are usually placed on a pedalboard and “are controlled by foot operation switches in order to leave the user’s hands free to play the instrument.” ’023 patent col. 1 ll. 35–38, 56–57.

Pro Stage Gear, LLC owns the ’023 patent. According to the ’023 patent, prior art pedalboards were essentially wooden boards to which guitar effects pedals were mounted. *Id.* at col. 1 ll. 56–61. If multiple guitar effects pedals were used, “they must be interconnected by cables to the original source of the sound to be altered, and then connected to the amplification system.” *Id.* at col. 1 ll. 42–45. These cables were “inserted into the adapters on the guitar effects and arranged between the pedals on the board. The wooden board may be placed in a carrying case and the cables covered by foam so that the cables are not exposed.” *Id.* at col. 1 ll. 58–61. With such setups, it was difficult to change out or add new effects “because the foam must be removed to uncover the cable connections, the effect removed from the board, the cables repositioned for the

new effect, the new effect positioned on the board, the cables rerouted, and the foam re-cut or replaced for the new effect.” *Id.* at col. 1 ll. 62–67. The ’023 patent explained that there was thus a need for “an improved pedal effects board which allows easy positioning and changing of the individual guitar effects while providing a confined and secure area for cable routing and placement.” *Id.* at col 2 ll. 1–4.

The ’023 patent describes a guitar effects pedalboard that purportedly solves these problems. Figure 7, reproduced below, shows a perspective view of example pedalboard 10. That example includes support structure members 30 and 32 and frame base 42, which elevates one side of pedalboard 10 from the stage floor. Pedalboard 10 also includes effect mounting surface 12 for mounting guitar effects and cable connection openings 14, 16, and 18 to “allow for the cable 56 to pass beneath the effect mounting surface 12 for connection to the guitar effect 46 mounted on top of the effect mounting surface 12.” *Id.* at col. 3 ll. 17–20. Figure 12, also reproduced below, shows an example pedalboard with eight attached guitar effects pedals.

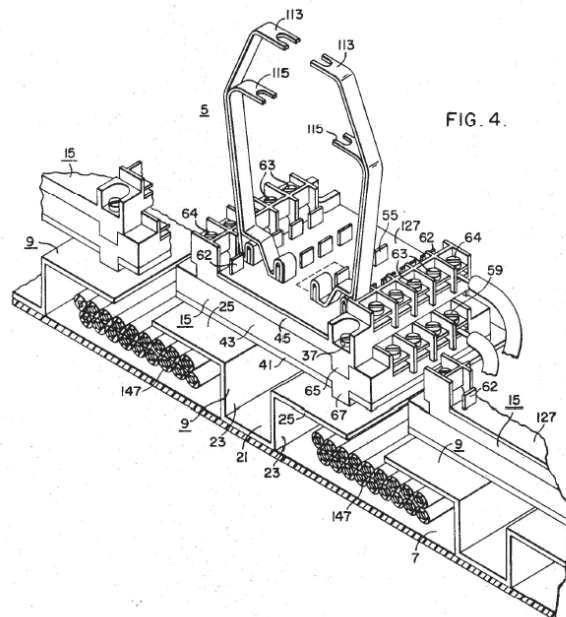
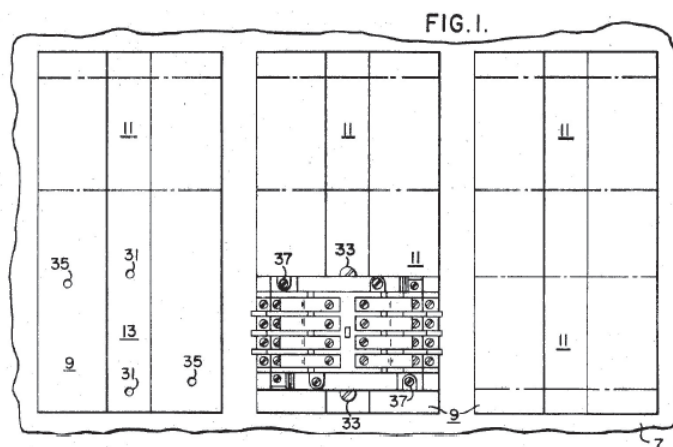




**FIG. 12**

II

Mullen relates to electrical relays. Mullen highlights that one “object of this invention is to provide an improved support for supporting one or more relay structures and for providing wiring-channel space for receiving wires that would be connected to the relay structures to connect the relay structures in various control circuits.” Mullen col. 1 ll. 50–54. An embodiment of Mullen’s support is depicted in Figures 1 and 4 below. Donner contends that these Figures depict a structure that is analogous to the structure claimed by the ’023 patent and that includes surfaces for mounting relays, cable connection openings, and area for routing cables. *E.g.*, Appellant’s Br. 14–17.



III

In its IPR petition, Donner set forth three grounds it contends render various claims unpatentable as obvious. Each ground relies, at least in part, on the teachings of Mullen. The Board determined that Donner's obviousness

challenge failed because Donner had not proven that Mullen is analogous art. *Decision*, 2019 WL 4020204, at \*9–11.

Donner appealed. We have jurisdiction under 28 U.S.C. § 1295(a)(4)(A).

#### DISCUSSION

“We review the [Board’s] factual findings for substantial evidence and its legal conclusions de novo.” *Redline Detection, LLC v. Star Envirotech, Inc.*, 811 F.3d 435, 449 (Fed. Cir. 2015). “Substantial evidence is something less than the weight of the evidence but more than a mere scintilla of evidence.” *In re Kotzab*, 217 F.3d 1365, 1369 (Fed. Cir. 2000).

The Board “must make the necessary findings and have an adequate ‘evidentiary basis for its findings.’” *In re NuVasive, Inc.*, 842 F.3d 1376, 1382 (Fed. Cir. 2016) (quoting *In re Sang Su Lee*, 277 F.3d 1338, 1344 (Fed. Cir. 2002)). In addition, the Board “must examine the relevant data and articulate a satisfactory explanation for its action including a rational connection between the facts found and the choice made.” *Id.* (quoting *Motor Vehicle Mfrs. Ass’n v. State Farm Mut. Auto. Ins. Co.*, 463 U.S. 29, 43 (1983)); see also *Princeton Vanguard, LLC v. Frito-Lay N. Am., Inc.*, 786 F.3d 960, 970 (Fed. Cir. 2015) (explaining that although the “Board is not required to discuss every piece of evidence,” it cannot “disregard [evidence] without explanation” or “short-cut its consideration of the factual record before it”). “This explanation enables the court to exercise its duty to review the [Board’s] decisions to assess whether those decisions are ‘arbitrary, capricious, an abuse of discretion, or . . . unsupported by substantial evidence.’” *NuVasive*, 842 F.3d at 1382 (quoting 5 U.S.C. § 706(2)(A), (E)).

#### I

Obviousness is a question of law based on underlying facts. *Eli Lilly & Co. v. Teva Parenteral Meds., Inc.*,

845 F.3d 1357, 1372 (Fed. Cir. 2017). These “factual inquiries” include “the scope and content of the prior art,” the “differences between the prior art and the claims at issue,” and “the level of ordinary skill in the pertinent art.” *Graham v. John Deere Co. of Kan. City*, 383 U.S. 1, 17 (1966).

Here, the Board concluded that Donner’s obviousness challenges, which rely on the teachings of Mullen, failed because Donner had not shown that Mullen falls within the scope of the prior art. Donner argues that the Board erred in reaching that conclusion. We agree.

The scope of the prior art includes all analogous art. *See, e.g., Princeton Biochemicals, Inc. v. Beckman Coulter, Inc.*, 411 F.3d 1332, 1339 (Fed. Cir. 2005); *In re GPAC Inc.*, 57 F.3d 1573, 1577–78 (Fed. Cir. 1995). “Two separate tests define the scope of analogous prior art: (1) whether the art is from the same field of endeavor, regardless of the problem addressed and, (2) if the reference is not within the field of the inventor’s endeavor, whether the reference still is reasonably pertinent to the particular problem with which the inventor is involved.” *In re Bigio*, 381 F.3d 1320, 1325 (Fed. Cir. 2004). Whether a reference is analogous art is an issue of fact. *In re ICON Health & Fitness, Inc.*, 496 F.3d 1374, 1378 (Fed. Cir. 2007).

It is undisputed that the ’023 patent and Mullen are not from the same field of endeavor. Therefore, the only question is whether Mullen is reasonably pertinent to one or more of the particular problems to which the ’023 patent relates.

Although the dividing line between reasonable pertinence and less-than-reasonable pertinence is context dependent, it ultimately rests on the extent to which the reference of interest and the claimed invention relate to a similar problem or purpose. *See, e.g., Wyers v. Master Lock Co.*, 616 F.3d 1231, 1238 (Fed. Cir. 2010) (concluding that prior art padlocks were analogous art because they “were clearly directed toward the same problem the inventor was

trying to solve in the” patent at issue); *GPAC*, 57 F.3d at 1578; *In re Clay*, 966 F.2d 656, 659 (Fed. Cir. 1992) (concluding that, where a “reference disclosure has the same purpose as the claimed invention, the reference relates to the same problem, and that fact supports use of that reference in an obviousness rejection”). Thus, when addressing whether a reference is analogous art with respect to a claimed invention under a reasonable-pertinence theory, the problems to which both relate must be identified and compared.

We conclude that the Board erred in its analysis of whether Mullen is analogous art. As an initial matter, the Board erroneously stated that Donner did “not put forth any argument or evidence to explain what would have compelled a pedalboard inventor in 1999 or 2000 to consider potential solutions arising from early 1970s-era relay technologies.” *Decision*, 2019 WL 4020204, at \*9. To the contrary, Donner submitted detailed expert testimony relevant to the inquiry. *See* J.A. 1521. Donner also argued in its petition and reply that Mullen was analogous art, supporting that argument with expert testimony and evidence from both the ’023 patent and Mullen. *E.g.*, J.A. 88–91, 104–12, 447–50. Thus, Donner set forth both arguments and evidence that Mullen is analogous art. Given the Board’s mistaken assertion to the contrary, it is unclear whether the Board meaningfully considered all of Donner’s arguments and evidence.

Moreover, even assuming that the Board did consider all relevant arguments and evidence, the Board also failed to properly identify and compare the purposes or problems to which Mullen and the ’023 patent relate.

For instance, the Board at one point stated that the “purpose of the ’023 patent” is “to mount guitar effects on a pedal board.” *Decision*, 2019 WL 4020204, at \*9. But substantial evidence does not support that statement. As the ’023 patent readily discloses, guitar effects had already



been mounted on a pedalboard. '023 patent col. 1 ll. 56–61. Thus, that could not possibly be a relevant purpose of the invention. Indeed, with respect to the analogous art inquiry, the relevant purposes of an invention are those relating to solving a problem. *See, e.g., Clay*, 966 F.2d at 659.

In addition, the Board's articulation of the purpose of or problem to be solved by the '023 patent is so intertwined with the patent's field of endeavor that it would effectively exclude consideration of any references outside that field.

The problems to which the claimed invention and reference at issue relate must be identified and compared from the perspective of a person having ordinary skill in the art ("PHOSITA"). *See, e.g., Sci. Plastic Prods., Inc. v. Biotage AB*, 766 F.3d 1355, 1360 (Fed. Cir. 2014) ("The analogous art inquiry is a factual one, requiring inquiry into the similarities of the problems and the closeness of the subject matter as viewed by a person of ordinary skill."). Importantly, this analysis must be carried out from the vantage point of a PHOSITA who is considering turning to the teachings of references outside her field of endeavor. *See Clay*, 966 F.2d at 660 (concluding that a reference was not reasonably pertinent where a PHOSITA "would not reasonably have expected to solve the [relevant] problem . . . by considering" that reference). Such a PHOSITA—resigned to considering art outside her field of endeavor—would thus not identify the problems so narrowly so as to rule out all such art.<sup>1</sup> The Board's

---

<sup>1</sup> One exception that has been contemplated, but not solidified, by our case law is where the problem a reference solves is so specific to its particular field of endeavor that a PHOSITA could not possibly describe the problem the reference solves other than in a manner that rules out all art outside that field. *See Sci. Plastic*, 766 F.3d at 1360. Neither party contends, nor do we believe, that this is such a case.

characterization of the problem to which the claimed invention relates effectively collapses the field-of-endeavor and reasonable-pertinence inquiries and ignores that the reasonable-pertinence analysis must be carried out through the lens of a PHOSITA who is considering turning to art outside her field of endeavor.

Later in its decision, the Board mentioned “a problem with cable routing and placement for effects pedal boards in 1999 or 2000.” *Decision*, 2019 WL 4020204, at \*10. By this statement, it is unclear whether the Board attempted to articulate a second purpose of or problem addressed by the '023 patent, whether it disavowed its originally articulated purpose, or whether it was merely acknowledging Donner’s position on the matter. In any event, the Board never meaningfully engaged with this articulation, compared this problem with any problems addressed by Mullen, or otherwise assessed whether Mullen was reasonably pertinent to this problem. Furthermore, it is unclear the extent to which the Board would have concluded that references outside the '023 patent’s field of endeavor might reasonably pertain to this problem.

Nor did the Board ever identify the problems to which Mullen relates. Because the Board failed to identify and compare the problems to which the '023 patent and Mullen relate, the Board failed to apply the proper standard.

The remainder of the Board’s analysis does not change our conclusion. For example, the Board identified a number of “significant differences between Mullen and the '023 patent.” *Decision*, 2019 WL 4020204, at \*9–10. But a reference can be analogous art with respect to a patent even if there are significant differences between the two references. *See, e.g., ICON*, 496 F.3d at 1380 (concluding that “[a]nalogous art to Icon’s application,” which related to “a treadmill with a folding mechanism and a means for retaining that mechanism in the folded position,” included “any area describing hinges, springs, latches,

counterweights, or other similar mechanisms—such as the folding bed in” the prior art). Indeed, there will frequently be significant differences between a patent and a reference from a different field of endeavor. But it does not follow that such a reference is, for that reason alone, not reasonably pertinent to one or more problems to which the claimed invention relates. Importantly, the Board did not attempt to explain how the differences it mentioned establish that the references were not directed to solving a similar problem.

The Board also explained that the relevant PHOSITA would have a “relatively low level” of skill and would have “had a poor understanding of Mullen’s relay technology.” *Decision*, 2019 WL 4020204, at \*9–10. While the level of skill in the art is certainly relevant to this inquiry and will continue to remain relevant on remand, the Board’s findings are, standing alone, insufficient to determine whether Mullen is analogous art. The relevant question is whether a PHOSITA “would reasonably have consulted” the reference in solving the relevant problem. *Heidelberger Druckmaschinen AG v. Hantscho Com. Prods., Inc.*, 21 F.3d 1068, 1071 (Fed. Cir. 1994). A PHOSITA might reasonably choose to consult a reference even if she would not understand every last detail of that reference, so long as she would understand the portions of the reference relevant to solving her problem well enough to glean useful information.<sup>2</sup>

---

<sup>2</sup> For example, here Donner need not show that a PHOSITA would understand the entirety of Mullen for Mullen to qualify as analogous art. Rather, the question is whether a PHOSITA would understand the relevant teachings of Mullen—i.e., the improved support structure as depicted in Figures 1 and 4—sufficiently well to use those teachings to solve her problem.

Furthermore, to the extent the Board relied on the differences in age between the '023 patent and Mullen in concluding that a PHOSITA would not have turned to Mullen, the Board did not adequately explain how Mullen's age relates to the problem Mullen solves or why a PHOSITA would not turn to Mullen's teachings.

Accordingly, we conclude that the Board applied the wrong standard when assessing whether Mullen was analogous art. We end this portion of our analysis by noting that the Board itself acknowledged that there may be "pertinent similarities" between Mullen and the '023 patent but concluded that those similarities, even if credited, did "not establish why [a PHOSITA] would have considered a reference from a different technology and time." *Decision*, 2019 WL 4020204, at \*9. To the contrary, if the two references have "pertinent similarities" such that Mullen is reasonably pertinent to one or more of the problems to which the '023 patent pertains, then Mullen is analogous art.

## II

Having concluded that the Board erred, we must now decide how to dispose of the appeal. Donner asks us to hold in the first instance that Mullen is analogous art because, in Donner's view, substantial evidence supports that conclusion. But, in general, appellate courts can rule on an issue of fact in the first instance only where "no reasonable fact finder could find otherwise." *Fox Factory, Inc. v. SRAM, LLC*, 944 F.3d 1366, 1374 (Fed. Cir. 2019). Although we conclude that the Board applied the wrong standard and might have failed to analyze certain arguments and evidence, we do not further hold that "no reasonable fact finder could conclude, under the proper standard," that Mullen is not analogous art. *Id.* Accordingly, we leave this factual issue for the Board to resolve on remand.

DONNER TECHNOLOGY, LLC v. PRO STAGE GEAR, LLC

13

CONCLUSION

We have considered the parties' remaining arguments but find them unpersuasive. For the foregoing reasons, we vacate and remand for further proceedings consistent with this opinion.

**VACATED AND REMANDED**

COSTS

Costs to Donner.